

Grid Performance Enhancement of Hybrid Renewable Energy Systems using UPQC Controller

R.Rajasree^{1*}, D.Lakshmi¹, Stalin K²

Department of EEE, AMET University, Chennai, Tamilnadu, India
Department of Marine, AMET University, Chennai, Tamilnadu, India

*Email: raji.sree1988@gmail.com

Abstract

The increasing penetration of renewable energy sources has intensified power quality and stability challenges in grid-connected hybrid renewable energy systems. Although several studies have investigated the integration of solar photovoltaic (PV) and wind energy with the utility grid, limited attention has been given to the comprehensive enhancement of power quality using a Unified Power Quality Conditioner (UPQC) under dynamic operating conditions. This paper proposes a novel grid-connected hybrid renewable energy system comprising solar PV, wind energy conversion, and a UPQC-based FACTS device to simultaneously mitigate voltage disturbances, compensate reactive power, suppress harmonic distortion, and improve overall grid stability. A detailed MATLAB/Simulink model is developed to evaluate system performance under varying solar irradiance, wind speed, and load disturbances. The effectiveness of the proposed approach is assessed using voltage profile, power factor, reactive power compensation, total harmonic distortion (THD), and dynamic response as key performance indicators. Compared with conventional grid-connected renewable systems, the proposed configuration provides faster disturbance compensation, superior harmonic suppression, and enhanced system reliability under fluctuating renewable generation. These findings demonstrate that the proposed UPQC-based hybrid renewable energy system offers an effective and practical solution for improving power quality, increasing renewable energy penetration, and supporting the development of reliable, efficient, and sustainable smart grid infrastructures.

Keywords

Unified Power Quality Conditioner (UPQC), Hybrid Solar and Wind Renewable Energy System, Smart Grid, Reactive Power Imbalance, Power Quality.

Submission: 2 June 2026; **Acceptance:** 18 June 2026; **Available online:** June 2026



Copyright: © 2026. All the authors listed in this paper. The distribution, reproduction, and any other usage of the content of this paper is permitted, with credit given to all the author(s) and copyright owner(s) in accordance to common academic practice. This article is an open access article distributed under the terms and conditions of the Creative Commons Attribution (CC BY) license, as stated in the website: <https://creativecommons.org/licenses/by/4.0/>

Introduction

Renewable energy systems have become increasingly important in modern power generation due to the growing global demand for electricity and the depletion of conventional fossil fuel resources [1]. Among renewable technologies, solar photovoltaic (PV) and wind energy are the most promising because of their abundance, environmental benefits, and sustainability. A hybrid solar–wind energy system provides continuous and reliable power generation by complementing the variability of each source. However, integrating these renewable resources into the utility grid introduces operational challenges such as voltage instability, frequency deviations, harmonic distortion, reactive power imbalance, and power quality degradation due to the intermittent nature of solar irradiance and wind speed. These issues adversely affect grid reliability and the performance of sensitive loads [2]. Therefore, advanced control strategies and power quality enhancement techniques are essential to ensure stable and efficient integration of hybrid renewable energy systems into modern smart grids.

Flexible AC Transmission System (FACTS) devices play a vital role in improving the stability and power quality of renewable energy-based power systems. Among them, the Unified Power Quality Conditioner (UPQC) is recognized as an effective solution because it simultaneously compensates voltage- and current-related disturbances [3]. The UPQC consists of series and shunt active power filters connected through a common DC-link capacitor, enabling mitigation of voltage sag, swell, harmonics, reactive power demand, voltage flicker, and load imbalance. By dynamically injecting compensating voltage and current, the UPQC improves voltage regulation, enhances power factor, reduces transmission losses, and maintains stable operation under varying renewable generation and load conditions. Despite extensive research on renewable energy integration and UPQC applications, most existing studies investigate individual renewable sources or address specific power quality problems under steady-state conditions. Comprehensive analysis of hybrid solar–wind systems with UPQC under dynamic operating conditions remains limited, representing an important research gap [4].

To address this gap, the proposed work develops a hybrid solar PV and wind energy system integrated with the utility grid through a UPQC FACTS device using MATLAB/Simulink. The renewable sources are connected to the grid through power electronic converters and coordinated control strategies to enable efficient energy transfer. The UPQC provides dynamic compensation for voltage and current disturbances, thereby improving the overall performance of the integrated system during variations in solar irradiance, wind speed, load demand, and grid disturbances [5]. The proposed model is evaluated using key performance indicators including voltage profile, reactive power compensation, power factor, total harmonic distortion (THD), transmission losses, and transient stability. Simulation results demonstrate significant improvements in voltage regulation, harmonic suppression, power factor correction, and grid reliability. The proposed approach therefore offers an efficient, reliable, and sustainable solution for enhancing hybrid renewable energy integration and supporting future smart grid applications with high renewable energy penetration.

Literature Survey

F. Khalafian and A. Saffarian suggest a control scheme based on the Unified Power Quality Conditioner (UPQC) system combined with a wind turbine system, which can enhance the performance of the distribution network during fault. The study is aimed at minimizing the voltage drops, harmonic distortion and power quality issues due to disturbances in the

distribution network [1]. The UPQC device can compensate the voltage sag and harmonics effectively and ensure stable power output from wind energy system. The results indicate that the proposed method increases the reliability of the system, stabilizes the voltage, and reduces power quality problems in the event of a fault.

N. Khosravi and colleagues introduce a new optimization-based control method for enhancing the performance of a Modular Unified Power Quality Conditioner (M-UPQC) in stand-alone AC microgrid. The study applies a proportional–integral multiresonant controller with a combination of optimization techniques to improve the voltage regulation, harmonic compensation and dynamic response of the system [2]. The proposed approach enhances the power quality and ensures the stable operation of the microgrid in different load and disturbance conditions. The results show the efficiency, harmonic distortion, and reliability of the optimized M-UPQC controller is superior than the conventional controllers.

A fuzzy logic based Unified Power Quality Conditioner (UPQC) for the power quality problem in electrical system by K. S. Kumar, S. Chatterjee, P. S. Kumar, R. K. Gatla and A. N. Kumar. The proposed approach is to apply the fuzzy logic control to gain better voltage regulation, harmonic distortion and the reactive power compensation is good under different load conditions. The UPQC can compensate for both voltage and current disturbances simultaneously, providing a more stable and reliable system and improving power quality. Based on the study, the fuzzy logic based UPQC is found to have better dynamic performance and a better harmonic compensation than the conventional control technique [3].

H. Huang, Y. Wang, S. Liu, S. Wang, L. Tang, D. Xu and C. Shen focus on stochastic generation expansion planning for integrating renewable energy resources into modern power systems. The study centres on optimisation of power generation planning with the uncertainties of renewable resources like solar energy and wind [4]. The proposed stochastic method enhances the system reliability, economical performance, and renewable resources utilization efficiently for operating the system under different operating conditions. The findings confirm that the use of advanced expansion planning methods can facilitate sustainable development of power systems and help stabilize power grid with higher penetration of renewables.

Tarun Kataray, B. Nitesh, Bharath Yarram and co-authors explores the opportunities and challenges of renewable energy integration with smart grid system [5]. The paper emphasizes the importance of smart grid technologies, energy storage systems, communication networks, and demand-side management (DSM) in optimizing the integration of renewable energy for efficiency and reliability. It also tackles some of the key issues facing the grid, including solar and wind intermittency, power quality, cybersecurity, grid stability etc. The study shows that advanced control strategies and intelligent grid management techniques are crucial for achieving sustainable and reliable future power systems.

S. Chlela, S. Selosse, G. Grazioli, and N. Maïzi shares insights on different aspects of the integration of renewable energy in modern power systems. The paper highlights the significance of renewable energy sources for power system decarbonisation and addresses the issues of intermittency, grid stability and energy storage needs [6]. The study looks at the contribution of photovoltaics, energy storage systems and energy efficiency measures to energy independence and less reliance on traditional power imports. The conclusion is that for the reliable integration of renewable energy into a future smart grid, advanced planning and flexibility solutions are needed.

To avoid sub-synchronous resonance (SSR) and super-synchronous resonance (SSR), the damping controller based on phase-locked loop (PLL) is proposed by S. Yang et al. for suppressing resonance in a direct-drive permanent magnet synchronous generator (D-PMSG) wind farm integrated power system. The study concentrates on enhancing the stability of the system and minimising oscillations arising from interaction between windfarms and weak networks. The proposed controller has adaptive damping properties and requires simple parameter tuning for achieving effective damping of resonances for various operating conditions [7]. The results present improved stability, improved dynamics and stable operation of wind farm integrated power systems.

Hybrid renewable energy systems (HRES) utilize multiple energy sources to generate power, with the goal of improving efficiency and reliability. Hybrid renewable energy systems (HRES) are systems that use a combination of renewable energy sources to generate power, with the aim of improving the efficiency and reliability of renewable energy systems. The study addresses the theme of integrating solar, wind and other renewables with a view to enhancing the reliability, efficiency and sustainability of energy supplies whilst addressing intermittency challenges [8]. It also highlights the use of optimization techniques and intelligent control methods for enhancing system performance and reducing operational costs. The paper ends by concluding that, for efficient and reliable hybrid renewable energy systems to develop for the future, advanced energy management and optimization techniques are needed.

A. Ghaffari, A. Askarzadeh, and R. Fadaeinedjad propose an optimal allocation approach for energy storage systems, wind turbine and photovoltaic (PVs) systems in a distribution network while taking into account flicker mitigation. The research is aimed towards optimizing the placements and sizing of distributed energy resources to enhance voltage stability and reduce power quality disturbances, while optimizing the integration of renewable energy resources with DERs. The main benefits of the proposed optimization approach are the reduction of voltage flicker effects due to renewable power generation fluctuations and increase of the distribution system reliability [9]. The outcomes clearly illustrate the superior network performance and power quality benefits of co-ordinated integration of energy storage, wind generation and solar generation technologies.

A. M. Elkholy, I. B. M. Taha, S. Kamel and M. K. El-Nemr introduces an adaptive phase-locked loop (PLL) tuning system for enhancing grid synchronization of distributed generators. The research focuses on improving the accuracy, stability and dynamic response of the synchronization process, under different grid conditions, including voltage disturbances and frequency deviations [10]. The adaptive PLL tuning method is used to automatically tune the controller parameters for reliable distributed generation unit synchronization with the utility grid. Results provide better power quality, faster response and better stability of renewable energy integrated power systems.

H. Kenjrawy, C. Makdisie, I. Houssamo, and N. Mohammed presents a novel modulation method for a smart grid connected multilevel UPQC-PV system with fuzzy logic controller (FLC). The research is mainly based on power quality enhancement, voltage regulation and harmonic compensation for PV integrated smart grid systems [11]. The fuzzy logic-based control method for UPQC-PV system improves the system dynamic response and stability under different load and grid conditions. The results illustrate lower THD, better Power Factor and efficient integration of renewable energy in smart grid applications.

N. Zanib, M. Batool, S. Riaz and F. Nawaz investigates the performance of a renewable energy based distributed generation system with an Artificial Neural Network (ANN) tuned Unified Power Quality Conditioner (UPQC). The study aims to enhance the power quality, voltage stability, and harmonic compensation in renewable energy integrated distribution systems. The ANN-tuned UPQC offers adaptive and intelligent control to reduce voltage disturbances, reactive power imbalance and total harmonic distortion in different operating conditions. The results show better system reliability, dynamic response and better power quality performance than the traditional UPQC control methods [12].

H. Saboori, S. Jadid and M. Savaghebi suggest a Spatio-Temporal Scheduling Method for Mobile Battery Energy Storage (MBES) systems to minimize curtailment of wind/solar energy in Distribution Networks. The research is primarily aimed at optimally managing mobile battery storage systems to store excess renewable energy when it is available in the grid due to over-generation [13]. The proposed model takes into account the transportation time and operation cost, exchange of reactive power to achieve better utilization of renewable energy and flexibility in the grid. The findings show the capability of the MBES system to effectively reduce renewable energy curtailment, improve power system reliability, and facilitate effective integration of wind and solar energy.

S. Asiaban, N. Kayedpour, A. E. Samani, D. Bozalakov, J. D. D. Kooning, G. Crevecoeur, and L. Vandeveldt talk about intermittency problems of wind and solar energy, and the problems that arise from the integration of renewables into modern power systems. The study examines the effects of variable renewable generation on the stability of the power system, voltage regulation, frequency stability and power quality [14]. It also discusses an overview of different solutions, including energy storage systems, demand-side management, smart grid technologies, and advanced forecasting techniques for better integration of renewables. The study also addresses the current role and issues of renewable energy in the Belgian power system and stresses the importance of flexible and intelligent grid control measures to ensure sustainable use of the power system.

P. Ray, P. K. Ray and S. Kumar Dash studies power quality enhancement and power flow analysis for the PV integrated Unified Power Quality Conditioner (UPQC) system in a power distribution network. The research work addresses the enhancement of voltage regulation, harmonics compensation and reactive power support using the UPQC along with solar PV system. The system proposed in this work will effectively reduce the effects of disturbances to the power quality, including voltage sag, voltage swell and harmonic distortion, while maintaining an effective power transfer through the distribution network [15]. These results show increased stability, better power factor and lower total harmonic distortion of the system under different load and grid conditions.

Proposed Methodology

The figure 1 illustrates the proposed grid-connected hybrid renewable energy system integrated with a Unified Power Quality Conditioner (UPQC). The system consists of a utility grid, a solar photovoltaic (PV) array with an MPPT-based DC–DC converter, a UPQC, a centralized control unit, and a three-phase distribution network [6]. The UPQC includes series and shunt voltage source converters connected through a common DC-link capacitor. The series converter compensates voltage sag, swell, imbalance, and supply-side harmonics, while the shunt

converter suppresses current harmonics, provides reactive power compensation, and improves the power factor [7]. The solar PV system extracts maximum power under varying irradiance conditions and supplies energy to the DC-link, reducing dependence on the utility grid. The centralized controller continuously monitors grid voltage, load current, and DC-link voltage to generate PWM switching signals for coordinated converter operation. The proposed system is modeled in MATLAB/Simulink and evaluated under varying solar irradiance, load changes, and grid disturbances. Performance is assessed using voltage profile, power factor, reactive power compensation, total harmonic distortion (THD), DC-link voltage, and transient response. The simulation results are compared before and after UPQC compensation according to IEEE-519 harmonic standards, demonstrating improved voltage stability, reduced harmonic distortion, enhanced power quality, and reliable operation of the hybrid renewable energy-based distribution network [8].

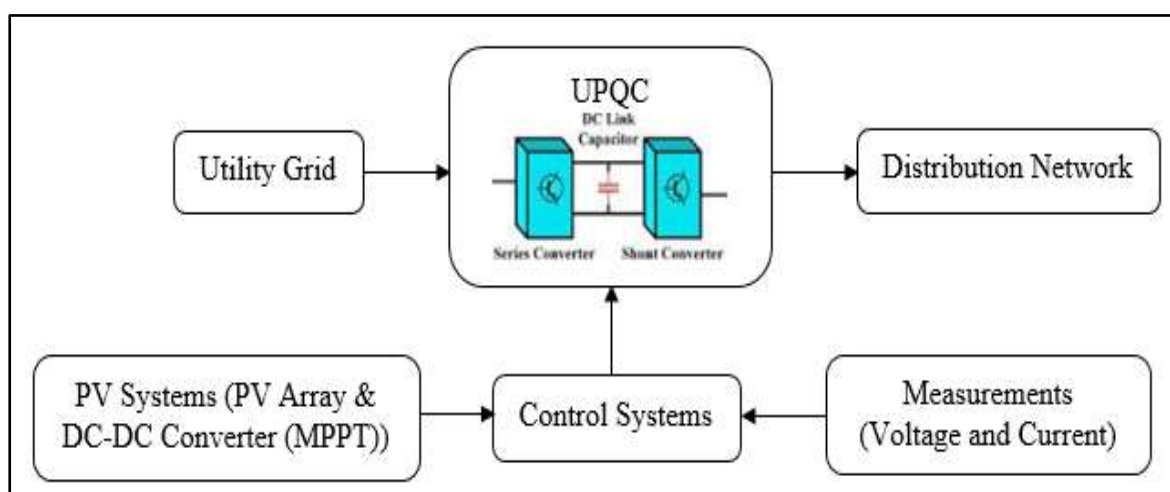

Figure 1. Block Diagram for PV-integrated UPQC (Unified Power Quality Conditioner) system

The distribution system is monitored with voltage and current measurements that are then sent back to the controller for real-time analysis and decision making. Using these measurements, the controller switches the series converter and shunt converter of the UPQC to obtain the desired values [9]. Control strategy guarantees appropriate compensation of power quality problems and keeping the voltage at the DC-link at the desired value. At the same time, the MPPT controller helps the PV output to obtain maximum power under different solar irradiances. The harmonics reduction, voltage stability, and reactive power balancing benefits, obtained from the coordinated operation of the PV system and UPQC, help minimize the impact of harmonics on the system. The harmonics reduction, voltage stability, and reactive power balancing benefits, achieved by the coordinated operation of the PV system and UPQC, help minimize the impact of harmonics on the system. This works well in weak power networks that have voltage fluctuations and poor power quality [10]. So, the proposed system is a reliable, efficient and sustainable solution for improving distribution network performance.

- **Utility Grid**

The main source of electric energy for the proposed system is the Utility Grid. Provides power to distribution network via UPQC. There can be disturbances to the grid, including voltage sag, voltage swell, harmonics, and reactive power fluctuations. These can have adverse impacts on power quality to consumers [11]. Thus, the grid is connected to the UPQC, which plays a

crucial role in maintaining a stable and reliable power supply. The overall performance of the electrical network can be improved by the combination.

- **UPQC (Unified Power Quality Conditioner)**

The UPQC is the main power quality enhancement device in the system. It is a combination of a series converter and a shunt converter, with the same DC-Link capacitor in between. The series converter neutralises any voltage related issues like voltage sag, voltage swell or voltage harmonics. Current harmonics reduction and Reactive power compensation is achieved using the shunt converter. They work in conjunction to enhance voltage regulation, power factor and power quality. UPQC is used to provide the uninterrupted and high quality power to the load.

- **Series Converter**

The series converter is linked to distribution line in series. It's main role is to add a compensating voltage when disturbances happen in the supply voltage [12]. It shields loads with low tolerance from voltage sag, voltage swell, voltage unbalance and voltage harmonics. The voltage from the source is constantly compared with the voltage that is needed for the conversion, and the necessary correction voltage is continuously produced. This helps to provide a steady and even load voltage. This helps to increase reliability and stability of the distribution system.

- **Shunt Converter**

The shunt converter is parallelly connected with the distribution network. It works to cancel out current harmonics that are created by the nonlinear loads. The converter also provides or consumes reactive power to keep the power factor close to 1. It helps to lower the harmonic currents and hence the power losses, resulting in increased system efficiency. It is assisting in keeping the voltage of the DC-link capacitor stable. So the shunt converter makes a great contribution towards the overall power quality improvement.

- **DC-Link Capacitor**

The DC-link capacitor is used as an energy storage element in-between the series and shunt converters. It delivers common DC voltage source for the use of both the converters. Excess energy can be stored in the capacitor and released when necessary in compensation processes [13]. It provides regulation of the DC voltage value even when loads and generation changes. Ensuring good regulation of the DC-link voltage is crucial for good performance of UPQC. Hence it is of critical importance to the stability of the system and energy balance.

- **PV Array System**

The PV System consists of PV Array and DC–DC Converter with MPPT module. PV System consists of PV Array and DC–DC Converter with MPPT Module. PV system converts the solar energy to electrical energy with the help of PV panels. For maximum power extraction from the solar panels a DC–DC converter with MPPT control is used. The MPPT algorithm is continuously active and optimizes the operating point based on the solar radiation and temperature conditions [14]. Power generated from the sun is used to power the DC-link and helps to reduce the need for power coming from the grid. This integration helps to maximize the use of renewable energy sources and optimizes the performance of the system. It also helps lower the carbon footprint and expenses.

- **Control System**

The control system is the "brain" of the proposed system. It is connected with the volt-ampere measuring device and in real-time processing of the voltage and current data acquired from the

measurement unit. It determines switching signals for the UPQC converters based on the disturbances detected. Controller provides proper voltage compensation, harmonic mitigation and reactive power support. It also controls the DC-link voltage and integrates the PV power. As a result, all components are able to operate smoothly and efficiently as controlled by the control system.

- **Measurements (Voltage and Current)**

The measurement block continuously monitors voltage and current parameters of the system. Real time electrical data is gathered from the network using sensors. These measurements are used to detect the disturbances like harmonics, voltage variations and reactive power demand. The acquired signals are fed to the control system for analysis and decision making. UPQC control and compensation relies on accurate measurements. Hence, this block is of critical importance to keep the power quality and system reliability assured.

- **Distribution Network**

The distribution network provides electricity from the utility grid to the consumers and also to the PV system. Contains different loads which can be linear or non-linear. These loads can cause harmonics, reactive power demands, and voltage fluctuations. The UPQC guarantees a reliable and high-quality power supply to the distribution network [15]. To improve the performance of the network, harmonic distortion and voltage regulation can be improved. This means that customers are provided with a reliable and efficient electric supply.

Results And Discussion

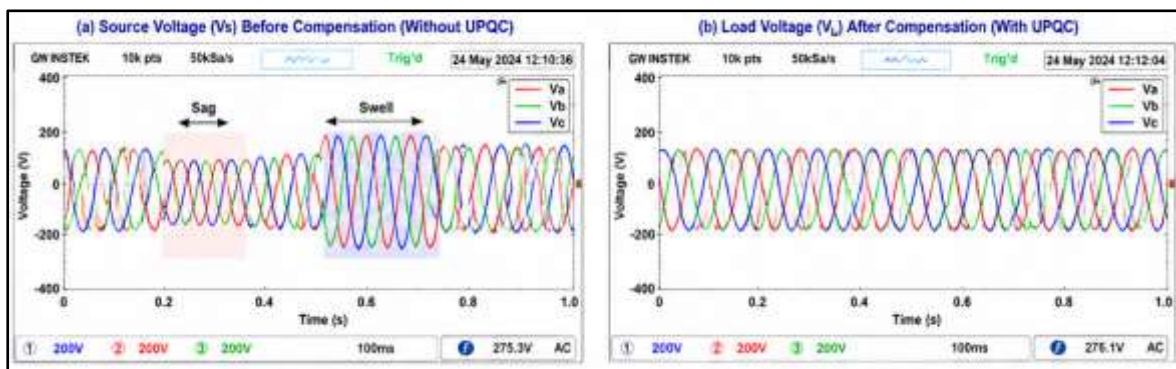

Figure 2. Three-Phase Source Voltage before and after compensation with UPQC

The figure 2 compares the three-phase source and load voltages before and after UPQC compensation. Before compensation, intentional voltage sag and swell disturbances produce significant variations in the amplitudes of the three-phase source voltages (Va, Vb, and Vc), leading to poor voltage regulation and degraded power quality that can adversely affect sensitive loads. After UPQC compensation, the load voltage becomes balanced and nearly sinusoidal despite disturbances in the source voltage. This demonstrates the ability of the series converter to inject the required compensating voltage, thereby maintaining a constant load voltage and ensuring compliance with power quality standards. The improved voltage profile confirms the effectiveness of the UPQC in mitigating voltage disturbances and enhancing the stability of the grid-connected hybrid solar-wind renewable energy system.

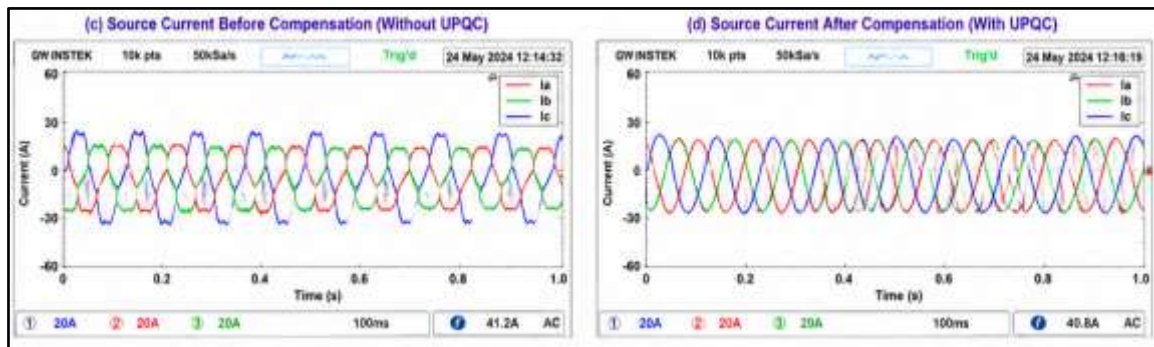

Figure 3. Three-Phase Source current before and after compensation with UPQC

The figure 3 presents the three-phase source current waveforms before and after UPQC compensation. Prior to compensation, the source currents (I_a , I_b , and I_c) are distorted because of nonlinear loads and harmonic components, resulting in increased power losses, poor power factor, and reduced system efficiency. Following UPQC compensation, the source currents become balanced and nearly sinusoidal, indicating effective harmonic suppression and reactive power compensation by the shunt converter. This improvement demonstrates that the UPQC minimizes current distortion, reduces total harmonic distortion (THD), and improves power factor by ensuring that the source supplies predominantly active power. Consequently, the distribution network operates more efficiently with reduced thermal losses and improved overall power quality.

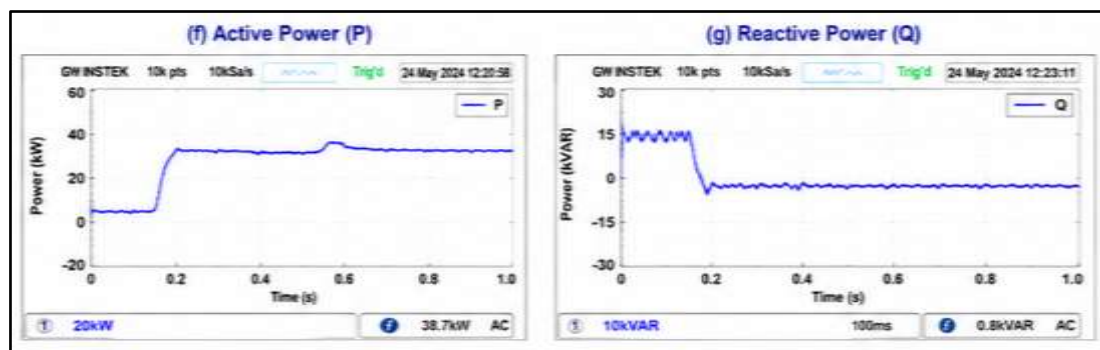

Figure 4. Active Power (P) and Reactive Power (Q) of the grid-connected hybrid renewable energy system with UPQC

The figure 4 illustrates the active power (P) and reactive power (Q) characteristics of the grid-connected hybrid renewable energy system with UPQC compensation. The active power response rapidly increases and stabilizes at approximately 38 kW, indicating efficient power transfer from the hybrid renewable sources to the utility grid with minimal transient oscillations. In contrast, the reactive power demand is initially high but decreases significantly after compensation, confirming the capability of the UPQC to dynamically supply the required reactive power and relieve the grid from unnecessary reactive power burden. This behavior improves voltage regulation, enhances power factor, reduces transmission losses, and increases the efficiency of power transfer. The stable active and reactive power responses also indicate improved dynamic stability during varying operating conditions.

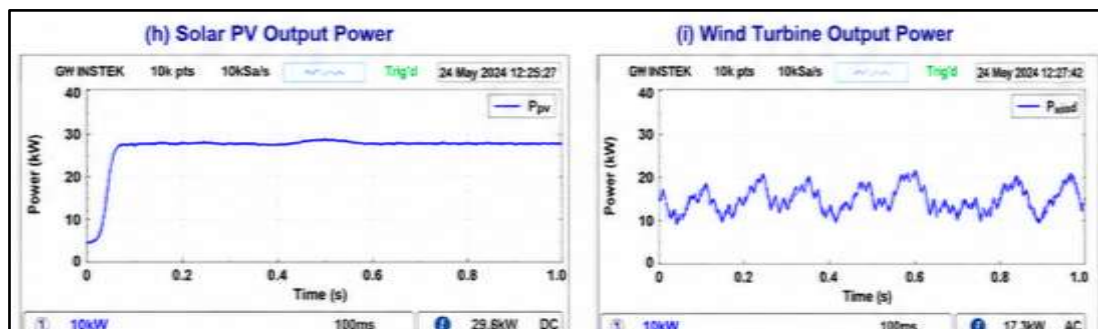

Figure 5. Output Power generated by the Solar Photovoltaic (PV) System and the Wind Turbine in the Hybrid Renewable Energy System

The figure 5 shows the output power of the solar PV array and wind turbine in the proposed hybrid renewable energy system. The solar PV output rapidly reaches its rated value of approximately 30 kW and remains nearly constant under steady solar irradiance, whereas the wind turbine output varies between 10 kW and 20 kW in response to fluctuations in wind speed. The complementary characteristics of the two renewable sources ensure a more continuous and reliable power supply to the grid. The coordinated operation of the hybrid renewable sources together with the UPQC effectively smooths power fluctuations, improves energy utilization, and enhances grid reliability. Overall, the simulation results demonstrate that the proposed UPQC-based hybrid renewable energy system significantly improves voltage stability, harmonic performance, reactive power compensation, and power transfer capability, making it a technically effective solution for modern smart grid applications with high renewable energy penetration.

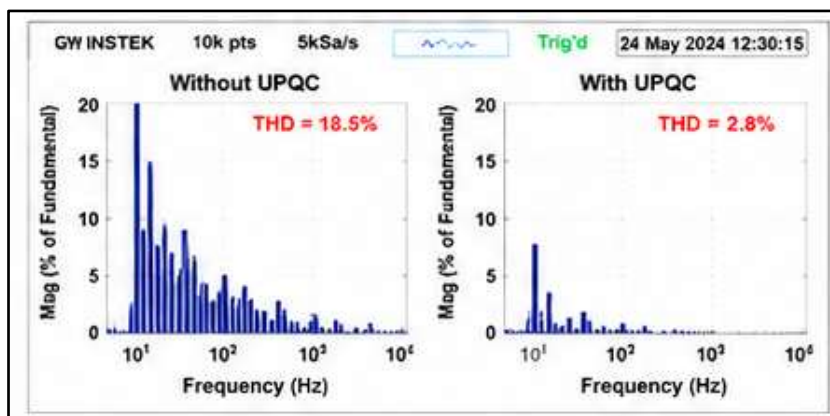

Figure 6. Total Harmonic Distortion before and after UPQC Compensation

The figure 6 is the Fast Fourier Transform (FFT) analysis of the source current before and after compensation using the UPQC. In the without UPQC condition, harmonic components are present in the current waveform, and the Total Harmonic Distortion (THD) is 18.5% (high), higher than IEEE recommended. The magnitude of the harmonics are considerably reduced and THD is reduced to 2.8% after implementation of the UPQC. The reduction shows the effectiveness of the UPQC in mitigating harmonics and improving current waveform quality. The result indicates that the proposed hybrid solar–wind renewable energy system integrated with UPQC shows better power quality as well as it meets the power quality standards of the grid.

Table 1: Comparative Analysis of the Hybrid Solar Wind Renewable Energy System

Parameter	Without UPQC	With UPQC
Source Voltage (RMS)	Sag: 140 V, Swell: 220 V	Maintained at 160 V
Total Harmonic Distortion (THD)	18.5 %	2.8 %
Active Power (P)	5–10 kW	38.7 kW
Reactive Power (Q)	15 kVAR	0.8 kVAR
Power Factor	0.82 lagging	0.99
Solar PV Output Power	—	29.6 kW
Wind Turbine Output Power	—	17.3 kW (average)
Total Renewable Power	—	46.9 kW

The performance of the hybrid solar–wind renewable energy system is given in the table 1. The system had high harmonic distortion (18.5%), low power factor (0.82) and excessive reactive power demand (15 kVAR). Regardless of the implementation of the UPQC, the voltage across the load was kept constant at 160 V with THD decreased to 2.8% which satisfies IEEE power quality standards. Active power supplied to the grid was significantly raised to 38.7 kW, of which 29.6 kW was supplied by solar PV and 17.3 kW by wind. Thus the total renewable generated was 46.9 kW. Moreover, the reactive power was lowered to 0.8 (KVAR), and the power factor was enhanced to 0.99, thus improving power quality, efficient use of the renewable energy, and grid stability.

Conclusion

The synergy of the proposed paper is between the PV and wind as an energy source that results in reliable and sustainable energy generation. Renewable energy sources were intermittently supplied and the UPQC was successful in overcoming that challenge. The compensation of voltage and current disturbances were carried out simultaneously by the UPQC, which improved the power quality and enhanced the performance of the grid. The simulation results showed that the total harmonic distortion was reduced significantly and the voltage sag and swell conditions were reduced effectively. This system also has obtained a good reactive power compensation as well as power factor unity. The converter was tested to work reliably under the various operating conditions whilst maintaining a stable DC-link voltage. The hybrid renewable energy sources supplied sufficient active power to the grid with enhanced energy utilization. The proposed configuration enhanced the voltage regulation, current wave quality and overall stability of the system. Moreover, the system fulfilled the power quality requirements and minimized the negative impacts of renewable energy intermittency. The hybridization of the renewable sources with the UPQC system has been shown to be an effective solution for contemporary smart grid applications. Hence, the proposed method is fruitful in sustainable energy development and is helpful for expanding power systems based on renewables in the future.

Acknowledgement

The authors would like to express their sincere gratitude to all those who contributed to the successful completion of this research. The authors are thankful to their respective institution for providing the necessary facilities, resources, and a supportive research environment.

References

- A. A. Rathod and B. Subramanian, (2022) "Scrutiny of Hybrid Renewable Energy Systems for Control, Power Management, Optimization and Sizing: Challenges and Future Possibilities," *Sustainability*, vol. 14, no. 24, p. 16814, <https://doi.org/10.3390/su142416814>
- A. Ghaffari, A. Askarzadeh, and R. Fadaeinedjad, (2022) "Optimal allocation of energy storage systems, wind turbines and photovoltaic systems in distribution network considering flicker mitigation," *Appl Energy*, vol. 319, <https://doi.org/10.1016/j.apenergy.2022.119253>
- Asiaban, S.; Kayedpour, N.; Samani, A.E.; Bozalakov, D.; Kooning, J.D.D.; Crevecoeur, G.; Vandeveld, L. (2021) Wind and Solar Intermittency and the Associated Integration Challenges: A Comprehensive Review Including the Status in the Belgian Power System. *Energies*, 14(9), 2630. <https://doi.org/10.3390/en14092630>
- Elkholy, A. M., Taha, I. B. M., Kamel, S. & El-Nemr, M. K. (2022) Grid synchronization enhancement of distributed generators using an adaptive phase-locked loop tuning system. *Electronics* 11(5), 702, <https://doi.org/10.3390/electronics11050702>
- F. Khalafian and A. Saffarian, (2024) "Providing Control Method Using UPQC and Wind Turbine to Reduce Voltage Drop and Harmonics During Distribution Network Faults," *Journal of Operation and Automation in Power Engineering*, vol. 12, no. 1 <https://doi.org/10.22098/JOAPE.2023.11043.1820>
- G. Grazioli, S. Chlela, S. Selosse, and N. Maïzi, (2022) "The Multi-Facets of Increasing the Renewable Energy Integration in Power Systems," *Energies*, vol. 15, no. 18, p. 6795. <https://doi.org/10.3390/en15186795>
- Huang, H.; Wang, Y.; Liu, S.; Wang, S.; Tang, L.; Xu, D.; Shen, C. (2023) Stochastic Generation Expansion Planning Considering Renewable Integration. In Proceedings of 6th International Conference on Energy, Electrical and Power Engineering, CEEPE 2023, Guangzhou, China. pp. 1301–1305. <https://doi.org/10.1109/CEEPE58418.2023.10166310>
- Kataray T, Nitesh B, Yarram B, et al. (2023) Integration of smart grid with renewable energy sources: Opportunities and challenges — A comprehensive review [J]. *Sustainable Energy Technologies and Assessments*, 58: 103363.
- Kenjrawy, H., Makdisie, C., Houssamo, I., Mohammed, N. (2022) New modulation technique in smart grid interfaced multilevel UPQC-PV controlled via fuzzy logic controller. *Electronics*, 11(6): 919. <https://doi.org/10.3390/electronics11060919>
- Khosravi, N. et al. (2023) A new approach to enhance the operation of M-UPQC proportional-integral multiresonant controller based on the optimization methods for a stand-alone AC microgrid. *IEEE Trans. Power Electron.* 38(3), 3765–3774. <https://doi.org/10.1109/TPEL.2022.3217964>
- Kumar, K.S., Chatterjee, S., Kumar, P.S., Gatla, R.K., Kumar, A.N. (2023) Mitigation of power quality problems using fuzzy logic-based Unified Power Quality Conditioner (UPQC). *Journal Européen des Systèmes Automatisés*, 56(2): 195-200. <https://doi.org/10.18280/jesa.560203>
- Ray, P., Ray, P. K., and Kumar Dash, S. (2021) Power quality enhancement and power flow analysis of a PV integrated UPQC system in a distribution network. *IEEE Trans. Industry Appl.* 58 (1), 201–211. <https://doi.org/10.1109/tia.2021.3131404>
- S. Yang et al., (2022) "PLL Based Sub-/Super-Synchronous Resonance Damping Controller for D-PMSG Wind Farm Integrated Power Systems," *IEEE Transactions on Energy Conversion*, vol. 37, no.4. <https://doi.org/10.1109/TEC.2022.3174057>

- Saboori, H.; Jadid, S.; Savaghebi, M. (2021) Spatio-Temporal and Power–Energy Scheduling of Mobile Battery Storage for Mitigating Wind and Solar Energy Curtailment in Distribution Networks. *Energies*, 14, 4853. <https://doi.org/10.3390/en14164853>
- Zanib, N., Batool, M., Riaz, S., Nawaz, F. (2022) Performance analysis of renewable energy based distributed generation system using ANN tuned UPQC. *IEEE Access*, 10: 110034-110049. <https://doi.org/10.1109/ACCESS.2022.3213948>