

Design of Obstacle Avoiding Robot

R. Jeyagopi

INTI International University, Persiaran Perdana, Putra Nilai, Negeri Sembilan, Malaysia.

Email: jeyag.raman@newinti.edu.my

Abstract

In today's world, robotics is fast growing and already interacting in many aspects of our daily lives. Robotics is part of communication advancement of technology; engineers have decided to work in this field to design or build robots which will make human life more advanced. There are various types of mobile robotics in today's technology world. There are tracks robot, humanoid robot, water-based robot, wheels robot and etc. Thus, obstacle avoiding robot is designed using three wheels in this research. The system is implemented using Arduino platform, android application and ultrasonic sensors. This robot has been developed with the interaction of Android-based device. Arduino Uno is used as the brain of the robot. It also includes the part of the software that utilizes a portable application. In this paper, obstacle avoiding robot is designed to allow the robot itself to navigate in unknown environment by avoiding obstacles using three wheels. The proposed design is compared with the four wheels in term of movement and turning. The outcomes show that the proposed design three wheels is able to provide a steady and faster movement and turning.

Keywords

Obstacle avoiding robot, Android Uno, Ultrasonic sensor

Introduction

In today's world, robotic is developing fast and has been a staple of advanced manufacturing for over half a century. As robots and their peripheral equipment become more sophisticated, reliable, and miniaturized, these systems are increasingly being utilized into real world settings in different fields such as military, medical fields, space exploration, and everyday housekeeping (Yan Peng, 2015). There are several types of robots used in today's technology world. Autonomous intelligent robots are the common mobile robots used in obstacle avoidance and path recognition that can perform desired tasks in unstructured environments without continuous human guidance (Z. Yan, Y. Zhao, S. Hou, H. Zhang & Y. Zheng, 2013). The obstacle detection is primary requirement of this obstacle avoidance robot using Android (A. C. Pavithra & V. Subramanya Goutham, 2018; D. Chakraborty, K. Sharma, R. K. Roy, H. Singh, & T. Bezboruah, 2016). The robot gets the information from surrounding area through mounted sensors on the robot.

The use of sensors, infrared (IR) sensor and ultrasonic sensor for developing an obstacle detection system had started as early as the 1980's (C. Rajan, B. Megala, A. Nandhini, & C. Rasi

International Conference on Innovation and Technopreneurship 2020

Submission: 4 September 2020; Acceptance: 9 September 2020



Copyright: © 2020. All the authors listed in this paper. The distribution, reproduction, and any other usage of the content of this paper is permitted, with credit given to all the author(s) and copyright owner(s) in accordance to common academic practice. This article is an open access article distributed under the terms and conditions of the Creative Commons Attribution (CC BY) license, as stated in the website: <https://creativecommons.org/licenses/by/4.0/>

Priya, 2015). Sensors are instruments which transform types of electricity into electrical energy. The sensors are bridges which connect the environment with different electronic devices (Joseph Azeta, Christian Bolu, Daniel Hinv & Abiodun A Abioye, 2019). The environment can be any physical environment such as smartphones, robots, tablets, intelligent clocks, such as military fields, airports, factories, hospitals, shopping malls, and electronic devices (Miguel Molina, Angelo Vera, Carolina Molina & Priscila Garzon, 2018). These systems have a wide variety of apps for industrial process control, protection, image and identification (R. Vairavan, S. Ajith Kumar, L. Shabin Ashiff & C. Godwin Jose, 2018). In this paper, obstacle avoiding robot is designed to allow the robot itself to navigate in unknown environment by avoiding obstacles using three wheels and Arduino Uno. The robot to drive the vehicle is powered by a lithium-ion battery. The Arduino board connects the battery circuit, the drive train motor circuit and other accessories.

Methodology

Figure 1 shows the system structure of the developed obstacle avoidance robot. In this studies, ultrasonic sensor, servo motor, motor driver and Android device are used to interact with each other. The L298N Motor Driver module is an integrated monolithic circuit in a 15 lead Multi watt and PowerSO20 packages. The L298N motor driver can simultaneously control 2 different DC motor. An ultrasonic sensor is a device which uses ultrasonic soundwaves determines the distance to an object from itself. Arduino Uno is an open source microcontroller board that has 14 digital input pins, 6 analog inputs, a 16MHz quartz crystal, a USB connection, a power jack, an ICSP header and a reset button (C. Rajan, B. Megala, A. Nandhini, & C. Rasi Priya, 2015; Arduino, 2015). The DC motor is one of the rotating electrical devices that transforms direct electrical current into mechanical energy to rotate the wheel. The Arduino board is connected to DC Motor through motor driver board (pin10, pin11, pin12, pin13) which provides power to the sensors. Sensors are used to direct the robot movement towards forward, backward, left and right. The movement of robot will stop whenever an obstacle is present on its path which ultrasonic sensors can detect.

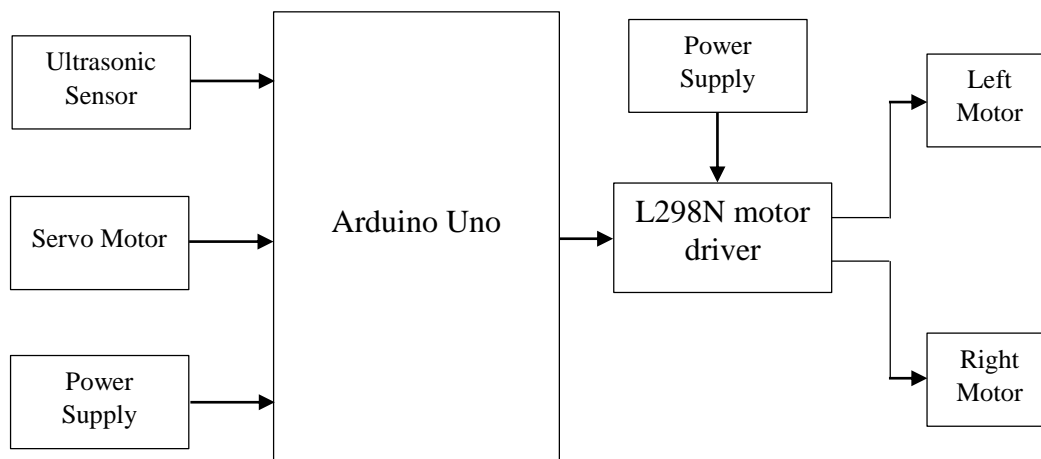

Figure 1. Structure of obstacle avoiding robot

Proposed Design

Circuit Diagram

The obstacle avoiding robot consists of Battery unit, Ultrasonic Sensor, Arduino Uno and DC Motors as shown in Figure 2. The Arduino Uno is a microcontroller board based on the ATmega328. The ultrasonic sensor HC-SR04 which has the primary function of sending a ping signal at regular intervals and waiting for response. The ultrasonic sensor is used in order to improve on sensitivity and reliability of existing systems. Two different power supplies were used in the system, a 9V volt battery which supply power to the microcontroller module and a 12V source regulated to 5V which was used to power the ultrasonic sensor. For the three-wheel obstacle avoiding robot, two servo motors were mounted to both the rear wheels and positioned side by side to ensure smooth and steady performance.

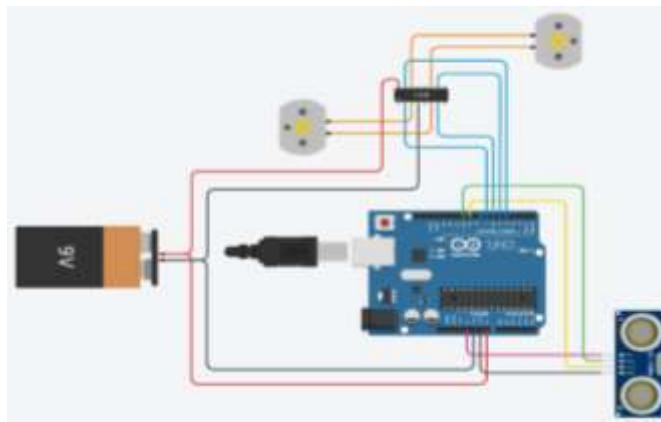

Figure 2: Obstacle avoiding robot circuit diagram

Chassis and prototype design

Figure 3 shows the obstacle avoiding robot chassis plate frame is designed using an impart-board which can fit the Arduino Uno R3, L298N, battery holder, and sensor. This 5mm thick robot chassis is cut into two pieces, covering the components and wiring at the middle. To accommodate various components used as well as to support the whole robot. The two chassis plates with the measurement of 170mm × 285mm in maximum width and height are designed. The plates are separated and supported by 6 pillars of length 30mm. Holes are placed on the plates for bolt and nut. The robotic frame of three-wheels mounted with two rear wheels and a front wheel, as shown in Figure 4. The rear wheels are made up of plastics, which are attached directly to the servo motor. A caster wheel is used due to its light weight in order to avoid overload of the robot. Figure 5 shows the four-wheeled robot frame mounted with two rear wheels and two front wheels respectively. The ultrasonic sensor is placed just on top of the robot high enough to follow the pavement of the lawn to avoid hitting the lawn. The body work of the robot is designed to accommodate all the essential components of the system.

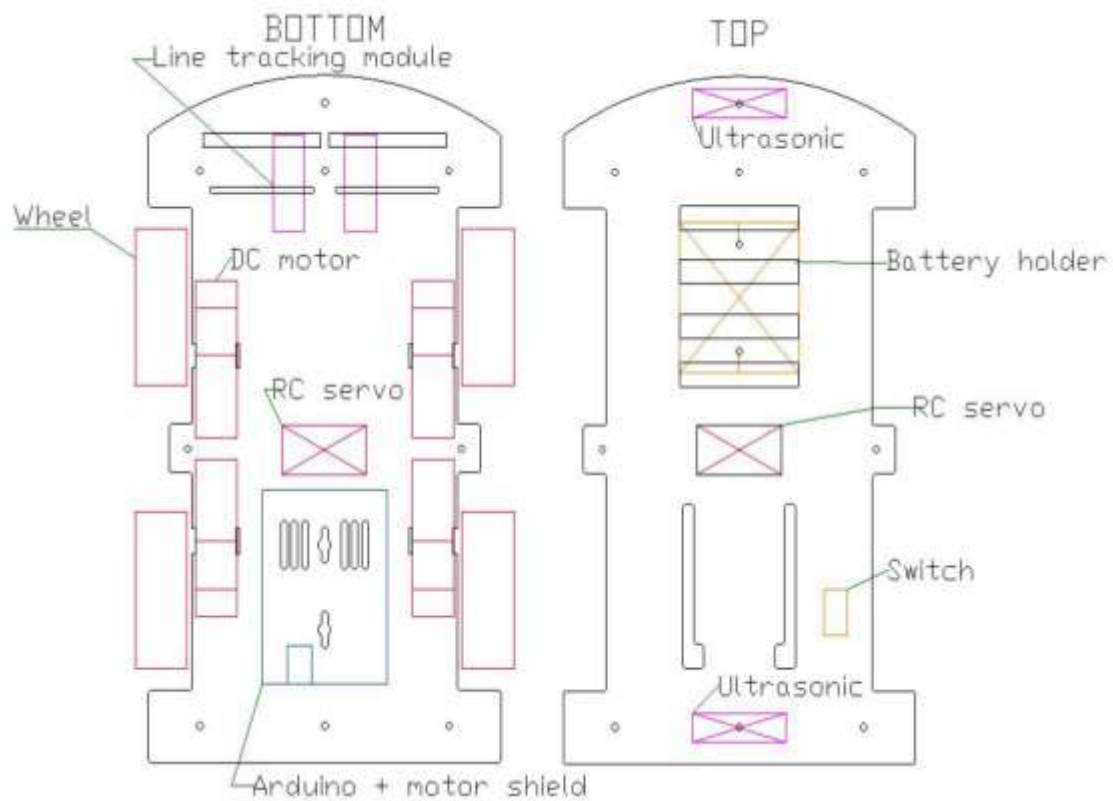

Figure 3. Robotic vehicle chassis design



Figure 4. Three-wheeled robot

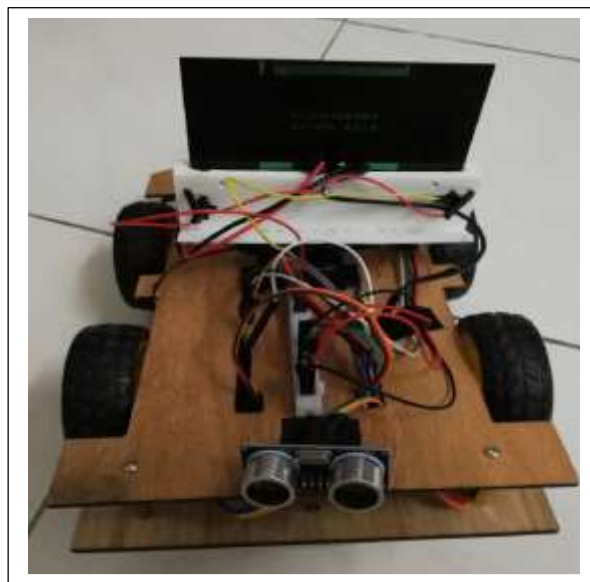

Figure 5. Four-wheeled robot

Software implementation

The system is implemented in C and C++ using the Arduino software. The data sent to the Arduino Uno from the Arduino application. Arduino Uno tracks incoming signals and informs the driver which signals are to be transmitted. Thus, the robot moves in a certain order according to the inputs entered. The flow chart in Figure 6 represents the methodology to drive the robot towards forward direction. If the ultrasonic sensor detects an obstacle less than 40 m ahead, the Arduino prompts the motor turn right and move forward. The ultrasonic sensor transmits a sound at 37 KHz and then waits to receive a corresponding echo from the sent signal.

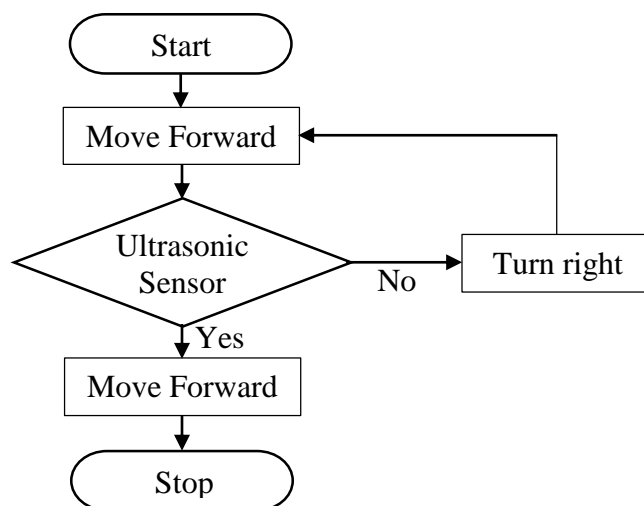

Figure 6. Proposed design flow chart

Results and discussion

Arduino and Motor voltage

The input voltage of each component measured from Arduino was shown in Table 1. The measured Arduino input voltage is 10.48V and the battery output is 11.1V. The input voltage for motor drivers is approximately 13~14V. Motors are used to drive the obstacle avoiding robot. The four-wheeled obstacle avoiding robot can rotate on ground by powering the motors on the left and right oppositely. When the robot turns right the motor will rotate in the clockwise direction. Therefore, motor on the left rotates forward while motor on the right rotates backwards. If the robot turns to left the motor should rotate anticlockwise. Thus, motor on the left rotates backwards while motor on the right rotates forward. The measured voltage for the motor, which is either the three-wheeled or the four-wheeled was shown in Table 1. The measured voltage for the motor is of the same value when the motor is moving at the same direction. However, the measured voltage increases when the motor turns left or right, while other side is zero. The measured voltage in three-wheel is higher than voltage drop in four-wheel. Thus, this will cause the three-wheeled obstacle avoiding robot to be steady, faster in movement and turning.

Table 1. Arduino and Motor Voltage

Component	Voltage measured from Arduino (V)	
Input to Arduino	10.48	
Input to Motor driver	13.38	
Motor	Voltage of Motor (V)	
	Three Wheel	Four Wheel
Robot moving forward		
Left front motor	0	3.33
Left back motor	3.43	3.36
Right front motor	0	3.36
Right back motor	3.43	3.33
Robot moving backward		
Left front motor	0	3.34
Left back motor	3.43	3.36
Right front motor	0	3.34
Right back motor	3.43	3.36
Robot turning right		
Left front motor	0	6.70
Left back motor	6.83	6.70
Right front motor	0	0
Right back motor	0	0
Robot turning left		
Left front motor	0	0
Left back motor	0	0
Right front motor	0	6.71
Right back motor	6.83	6.71

Conclusions

There are many papers designed with Arduino Uno, Raspberry pi and Android platform to address obstacle avoiding robot. Obstacle avoiding robot is developed using Arduino platform, android implementation and ultrasonic sensor in these studies. Arduino Uno has been used as the robot's brain. It also involves the portable application portion of the software. The robot's fundamental motions are given by taking input from the Android application. A degree of accuracy and minimum probability of failure is obtained. The commissioning of such a robot can improve its effective operation and control its tasks remotely and wirelessly. Thus, the evaluation on the three-wheel obstacle avoiding robot system shows that it is capable of avoiding obstacles, ability to avoid collision and change its position.

Acknowledgements

We would like to thank INTI International University, Malaysia for supports in the research.

References

- A. C. Pavithra and V. Subramanya Goutham, "Obstacle Avoidance Robotic Using Arduino", International Research Journal of Engineering and Technology (IRJET), Vol:6, 2018.
- Arduino. (2015). Arduino Software (IDE). (Arduino) Retrieved December 27, 2015, from <https://www.arduino.cc/en/Guide/Environment>.
- C. Rajan, B. Megala, A. Nandhini, and C. Rasi Priya, "A Review: Comparative Analysis of Arduino Micro Controllers in Robotic Car", World Academy of Science, Engineering and Technology International Journal of Mechanical, Aerospace, Industrial and Mechatronics Engineering Vol:9, No:2, 2015.
- D. Chakraborty, K. Sharma, R. K. Roy, H. Singh, and T. Bezboruah, "Android application based monitoring and controlling of movement of a remotely controlled robotic car mounted with various sensors via Bluetooth," 2016 IEEE International Conference on Advances in Electrical, Electronic and Systems Engineering (ICAEES), 2016.
- Joseph Azeta, Christian Bolu, Daniel Hinvi and Abiodun A Abioye, "Obstacle detection using ultrasonic sensor for a mobile robot", 2019 8th International Conference on Mechatronics and Control Engineering, 2019.
- Miguel Molina, Angelo Vera, Carolina Molina and Priscila Garzon, "Design and Construction of an Obstacle Avoiding Robot Based on Arduina Platform and Programming Too", 2018 9th IEEE Annual Ubiquitous Computing, Electronics & Mobile Communication Conference (UEMCON), 2018.
- R. Vairavan, S. Ajith Kumar, L. Shabin Ashiff and C. Godwin Jose, "Obstacle Avoidance Robotic Vehicle Using Ultrasonic Sensor, Arduino Controller", International Research Journal of Engineering and Technology (IRJET), Vol:5 2018.
- Yan Peng et al., "The Obstacle Detection and Obstacle Avoidance Algorithm Based on 2-D Lidar", IEEE International Conference on Information and Automation, pp. 1648-1653, Aug 2015.
- Z. Yan, Y. Zhao, S. Hou, H. Zhang and Y. Zheng, "Obstacle Avoidance for Unmanned Undersea Vehicle in Unknown Unstructured Environment", Mathematical Problems in Engineering, vol. 2013.