

Investigation on Viability of Solar Panel Covered Carpark Project for Inti International University

Chih Yong Tan¹, Seyed Amirmostafa Jourabchi^{1*}, Hoon Kiat Ng², Suyin Gan²

¹Faculty of Engineering and Quantity Surveying, INTI International University, Jalan BBN 12/1, Bandar Baru Nilai, 71800 Nilai, Negeri Sembilan, Malaysia

²Faculty of Engineering, The University of Nottingham Malaysia Campus, Jalan Broga, 43500 Semenyih, Selangor, Malaysia

Email: amir.jourabchi@newinti.edu.my

Abstract

This project aimed to study feasibility of implementing solar panels into Inti International University, Nilai academic block carpark area, forming solar carports. Capital calculation as well as breakeven calculation for the whole project are predicted in order to examine viability of project in long run. First of all, measurement of planned covered parking area was carried out and estimated total covered area is about $8520m^2$ to cover 822 parking slots. A shading analysis has been carried out on planned covered area as shading impact may affect performance of panels and creating hotspot on shaded cells and eventually damage solar cells. Based on above, parking area located near sport facilities of Inti Academic Block were considered. Carports structure to cover such area has been designed and cost of carports structure is about RM190k. For solar system, a real quotation has been requested from Solar Company named Plus Solar in order to obtain an accurate calculation of capital where solar system consists of 72 pieces of JA Solar 375Wp Monocrystalline panels, forming a 27kwp (kilowatt-peak) solar system that potentially saves an average of RM 15k per year. As cost for solar system is RM 194,400, the total capital of this solar carport project is approximately RM 465k. By considering tax incentives provided by government including GITA & CA tax incentives, and in addition consideration of 0.65% for annual derating of solar system and 3% of increment for OPEX annually, as well as RM 14,924.29 of average annual electricity bills saving (for 30year), and this solar carport project requires 25 years and 2 months (25.17years) to reach its breakeven point.

Keywords

Solar panel, solar carport, feasibility study.

Introduction

The rapid growth of population and economics has contributed to extremely high demand for electricity. However, traditional electricity production method by fossil fuel is proven to be a major contribution of increasing emission of greenhouse gases from year to year. Statistical data shown

that amount of carbon dioxide for the first time has surpassed four hundred parts per million (400ppm) in year 2013 (NASA's Jet Propulsion Laboratory, 2018) and the number is still increasing today. Therefore, alternatives of energy production with renewable energy will be new trend as it is pollution-free and is infinite. According to International Energy Agency, in year 2016, there are about 2/3 of new powers are renewable energy (Vaughan,A, 2017). Solar Energy is one of renewable energy where irradiation emitted by sun is used to generate electricity and it is clean and pollution free. However, people often claim that solar panel would require large area of land to produce sufficient electricity for daily usage. By implementing solar panels into carpark area would be a good choice to utilize uncovered carpark space and to maximize land usage. However, in Malaysia, utilization of carpark area by installing solar panel is rarely being used.

Inti International University is an educational institution that handle thousand of students which indicated that Inti would require high power consumption. In Inti's academic block area, there are about $8520m^2$ open space carpark area that is directly exposed to sunlight and by placing solar panels to cover opened space carpark area, forming solar carports will be a good choice as solar panels can provide shading for carpark area. Therefore, implementation of solar carports in Inti International University will be investigated in this project.

Methodology

After a detail shading analysis on planned covered area, most of them are under shade where shading may reduce performance of overall solar system significantly and it may lead to hotspot on panels (Rossi.D, Omana.M, Giaffreda.D, Metra, n.d.). that will eventually damage solar cells (García, M. C. A, Herrmann,W, Bohmer, W, and Proisy, B, 2003), (Kovach,A, Schmid,J, 1996) thus increase overall cost of project which will increase period require for ROI .Therefore, there is only one parking area feasible for solar carports which is parking area near sport facilities as attached in Figure 1 below that able to cover 33 parking slots with an estimated area of $497.82m^2$.



Figure 1. Top view of parking area that is feasible for solar carports.

As carports structure will be required for placing solar panels on top, forming solar carports, so carports structure has to be designed in order to fit parking area and to support weight of solar panels (22kg each). The structure of carports is designed as below shown in Figure 2 and Figure 3.

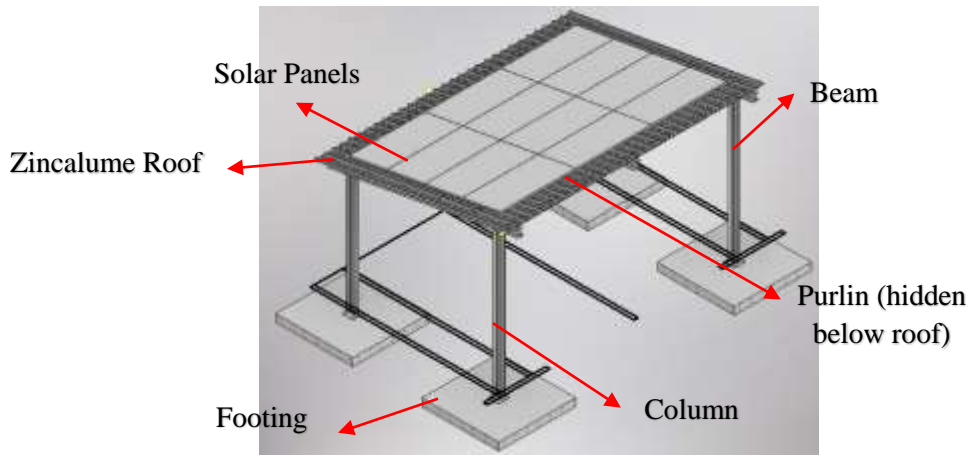

Figure 2. 3D Design for carports structure (for two parking slots)

INTI JOURNAL

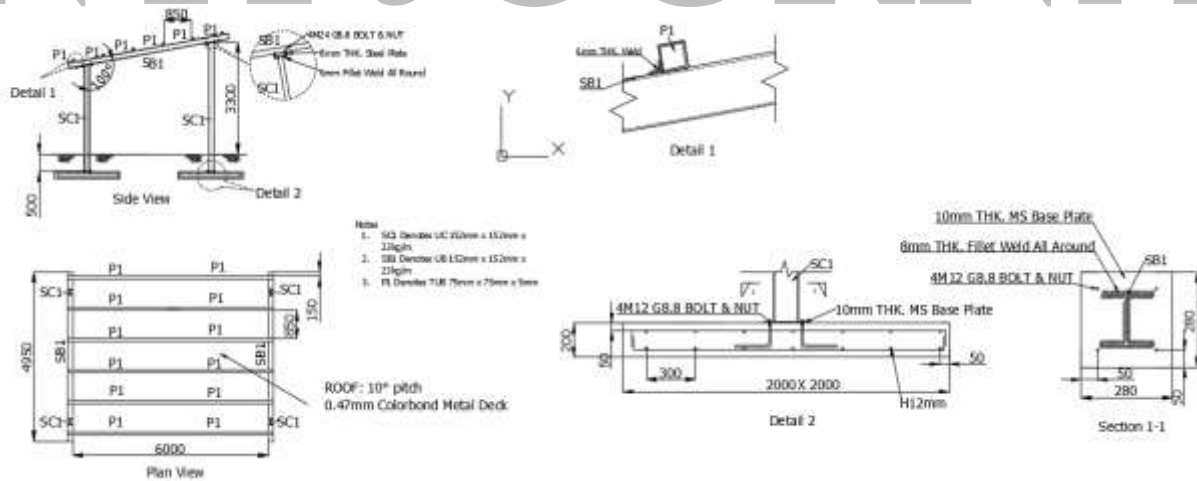

Figure 3. Construction 2D drawing for carports structure.

Results and Discussion

For solar system, basically there are two common solar system connection available in market nowadays which is on-grid and off-grid solar system. In this project, on-grid solar system is selected where solar system is connected to grid system due to its high reliability and accessibility to grid system. Overall, on-grid system able to provide stable electricity supply and it is a cost-effective choice as battery installation and maintenance is not an issue in on-grid system.

Moreover, for selection of type of solar panels where monocrystalline panel is selected in this project. The reason behind is due to limited space available, therefore monocrystalline panels that typically higher performance will be implemented to maximize the power produce.

Table 2. Summary of specifications for components for solar system.

Components	Info of Components	Quantity
PV Module	JA Solar 375Wp Mono PERC (JAP72S01-375) 1) Dimensions: 1960mm x 991mm x 40mm 2) Rated Max Power at NOCT: 276W 3) Temperature Coefficient of Pmax: -0.38%/°C 4) NOCT: 45 ± 2 °C 5) Module Efficiency: 19.3%	72
Inverter	Huawei Sun-2000 12 kTL	2
Mounting Structure	Anodized Aluminium mounting structures with stainless clamps, bolts, nuts and washers	-

Table 3. PV system layout and details

System Configuration	
System Capacity	27 kWp (kilowatt-peak)
Roof type	Metal Deck (0.47mm Zinalume)
PV Module Orientation	Landscape

For performance of solar panels, assumed rated maximum power at NOCT = 276W and each panel will generate an average of 5 hours of maximum power per day as well as there are 30 days in a month averagely, estimated electricity generated per month is about 2.981MWh. To ensure the result is valid, calculated result is compared with PVSyst simulation result provided by Plus Solar where solar system will be able to produce 2.93MWh based on simulation result. With this, the result is valid as percentage error is less than 3% and estimated electricity produced per month for proposed solar system is 2.93MWh per month.

For capital calculation, it can be divided into two main category which are capital of solar system and capital of carports construction. By estimating materials cost of carports as well as labor cost for completing construction of carports, capital of carports is approximately RM229,036.84 meanwhile for solar system costing, a real quotation is requested from Plus Solar for an accurate breakeven calculation and the capital of solar carports is RM 194,400 (Plus Solar, 2018). So, the total capital for the project would be RM 423,436.84. In Malaysia, installing green technology will be eligible for enjoying tax incentives offered by government which is Capital Allowance (CA) and Green Technology Tax Incentives (GITA). For GITA, the tax incentives will be applied on qualifying CAPEX incurred on green tech project during period of year 2013 to year 2020 where ITA (investment tax allowance) will be given to the companies (MIDA, 2018). Meanwhile for CA, according to Schedule 3 of Income Tax Act 1967, capital allowance is being introduced that allowed deductions of tax in form of allowance (HasilNet.Org, 2018) where for solar panels are known as part of Plant and Machinery asset type, therefore allowance offered would be 20% of initial allowance and 14% of annual allowance (Inland Revenue Board of Malaysia). In this project, CA able to save around RM 50k in a total period of six year meanwhile GITA able to save another RM 47k. By assuming 0.65% annual derating of solar system, 10% of

TNB tariff increment for every five years as well as a 3% of annual OPEX increment and green technology tax incentives offered by Malaysia Government, financial analysis of project for 30years can be calculated.

Table 5. Financial Analysis of solar carports project for 30years.

Year	PV Generation (kwh/year)	Consumption Saving (RM)	Tariff Rate (RM)	GITA (RM)	CA (RM)	Capital (RM) & OPEX (Start from year 1)	Accumulated Saving (RM)
0	-	-	-	-	-	423436.84	-
1	35208	12,850.92	0.365	15,863.04	46,656	-891	-348957.88
2	34979	12,767.33		6531.84		-917.73	-321134.92
3	34751	12,684.11		6531.84		-945.27	-302753.48
4	34525	12,601.62		6531.84		-973.63	-284482.8
5	34300	12,519.50		6531.84		-1002.84	-266322.97
6	34077	13,698.95	0.402			-1032.93	-248274.47
7	33855	13,609.71				-1063.92	-230942.85
8	33634	13,520.86				-1095.84	-218397.06
9	33415	13,432.83				-1128.72	-205972.04
10	33197	13,345.19				-1162.59	-193667.93
11	32981	14,577.60	0.442			-1197.47	-181485.33
12	32766	14,482.57				-1233.4	-168105.2
13	32553	14,388.42				-1270.41	-154856.03
14	32341	14,294.72				-1308.53	-141738.02
15	32130	14,201.46				-1347.79	-128751.83
16	31921	15,513.60	0.486			-1388.23	-115898.16
17	31713	15,412.51				-1429.88	-101772.79
18	31506	15,311.91				-1472.78	-87790.16
19	31301	15,212.28				-1516.97	-73951.03
20	31097	15,113.14				-1562.48	-60255.72
21	30894	16,497.39	0.534			-1609.36	-46705.06
22	30693	16,390.06				-1657.65	-31817.03
23	30493	16,283.26				-1707.38	-17084.62
24	30294	16,176.99				-1758.61	-2508.74
25	30097	16,071.79				-1811.37	11909.64
26	29901	17,581.78	0.588			-1865.72	26170.06
27	29706	17,467.12				-1921.7	41886.12
28	29512	17,353.05				-1979.36	57431.54
29	29320	17,240.16				-2038.75	72805.23
30	29129	17,127.85				-2099.92	88006.64

Breakeven Point !

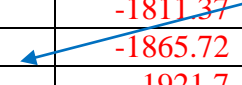

From table 5, the period required for ROI (return of investment) is at 25.17 years which means that breakeven point of the project occurs at that point where total revenue is equal to total capital of project and annually the solar system able to save approximately RM 15k of electricity bills.

Conclusions

As this project serves to investigate feasibility of solar carports by covering Inti academic block parking premises with solar panel, the overall cost of project and breakeven point of project has to be figured out to check viability of project in long run. However, after a detail analysis most of the parking spots are not suitable due to shading impact since performance of solar system will be affected significantly and it may lead to hotspot phenomena and eventually will cause constructive effect on PV modules. Therefore, in Inti academic block parking area there is only one parking area is suitable for solar carports which is parking area located near sport facilities. Shading analysis has been applied on parking area near sport facilities as well, although there is no shading impact of trees, however futsal court spot light will cause constant shading to that parking area, therefore number of solar panels have to be reduced from 204 pieces to 72 pieces in order to avoid shading of lamp poles. Besides, due to carpark orientation, less cost-effective option of single row parking carports has to be implemented in this case.

In conclusion, all of the objectives have been achieved as total capital of solar carports project in parking area near sports facilities has been figure out as well as the design of solar carports for placement of solar panels had been included and this project requires 25years and 2 months (25.17years) to reach its breakeven point.

Acknowledgements

The authors would like to acknowledge Faculty of Engineering and Quantity Surveying of INTI International University for their support towards this work.

References

- Aggarwal, V. (2018). How to Calculate Solar Panel Payback Period (ROI). [Online]. Available at: <https://news.energysage.com/understanding-your-solar-panel-payback-period/> [Retrieved on 22 January 2019]
- García, M. C. A, Herrmann, W, Bohmer, W, and Proisy, B. (2003). "Thermal and Electrical Effects caused by Outdoor Hot-Spot Testing in Associations of Photovoltaic Cells," Progr. Photovolt., Res. Appl., vol. 11, no. 5, pp. 293–307.
- HasilNet.Org. (2018). Capital Allowance Types and Rates. [Online]. Available at: <https://www.hasilnet.org.my/capital-allowance-types-rates/> [Retrieved on 23 December 2018]
- Inland Revenue Board of Malaysia. (2015). Qualifying Expenditure and Computation of Capital Allowances. [Online]. Available at: http://lampiran1.hasil.gov.my/pdf/pdfam/PR_6_2015.pdf [Retrieved on 23 December 2018]

2018]

- Kovach, A and Schmid, J. (1996). "Determination of Energy Output Losses due to Shading of Building-Integrated Photovoltaic Arrays using a Raytracing Technique," *Solar Energy*, vol. 57, no. 2, pp. 117–124.
- MIDA. (2018). Tax Incentives for Green Industry. [Online]. Available at: <http://www.mida.gov.my/home/tax-incentives-for-green-industry/posts/> [Retrieved on 17 December 2018]
- NASA's Jet Propulsion Laboratory. (2018). *Graphic: The Relentless Rise of Carbon Dioxide*. [Online]. Available at: https://climate.nasa.gov/climate_resources/24/graphic-the-relentless-rise-of-carbon-dioxide/ [Retrieved On 11 October 2018]
- Plus Solar. (2018). Engineering, Procurement, Construction and Commissioning proposal of a 27kWp Photovoltaic System at Persiaran Perdana BBN, Putra Nilai, 71800 Nilai, Negeri Sembilan for Inti International University. [PDF File]. Provided by Plus Solar on 14 November 2018.
- Plus Solar. (2018). Proposed Mounting Structure. [PDF File]. Provided by Plus Solar on 10 October 2018.
- Rossi.D, Omana.M, Giaffreda.D, Metra. (n.d.). *Modeling and Detection of Hotspot in Shaded Photovoltaic Cells*. [Online]. Available at: <https://core.ac.uk/download/pdf/29045732.pdf> [Retrieved on 23 December 2018]